

# ATKOMATIC

## 2000 Series

Stainless Steel, Direct Lift to 10,000 psig (690 bar)  
Medium Pressure Valve Configurable for Variety of Fluid Applications



### Features

- Direct acting valve
- Pressure to 10,000 psig (690 bar) depending on fluid and orifice size
- Barstock body construction
- Stainless steel construction on all wetted parts: 316 for pressure containing parts and plunger material is 416 stainless that is treated for increased corrosion resistance
- Will handle fluids with viscosity up to 200 SUS
- Fluid temperatures from  $-423^{\circ}$  to  $+500^{\circ}$  F ( $-253^{\circ}$  C to  $260^{\circ}$  C)
- Suitable for use with wide variety of fluid including: air, gasses, liquids, hydraulic fluids, steam, cryogenic fluids, and corrosive fluids
- Optional seat materials of Teflon<sup>®</sup>, Kel-F<sup>®</sup>, Buna N, Viton<sup>®</sup>, EPR, or 316 stainless steel depending on fluid type and pressure. These are available with  $\frac{1}{16}$ " through  $\frac{3}{16}$ " orifices
- Seat material is Stellite<sup>®</sup> with  $\frac{1}{32}$ " and  $\frac{3}{64}$ " orifices
- Body seal materials of Teflon<sup>®</sup>, Viton<sup>®</sup>, Buna N, or EPR.
- Flow orifice sizes of  $\frac{1}{32}$ ",  $\frac{3}{64}$ ",  $\frac{1}{16}$ ",  $\frac{3}{32}$ ",  $\frac{1}{8}$ ", and  $\frac{3}{16}$ "
- Pipe sizes of  $\frac{1}{8}$ ",  $\frac{1}{4}$ ",  $\frac{3}{8}$ ", and  $\frac{1}{2}$ " NPT
- British BSPT, AND, and AMINCO ports available
- Cv from 0.020 to 0.72
- Can use a class H double wound coil (requires use with a relay to drop put primary coil winding after valve actuation) depending on pressure
- Coil housings available in NEMA 1 (standard), NEMA 4 (waterproof), NEMA 7 (explosion-proof for hazardous locations), and combination NEMA 4 & 7
- Class H coil is standard

### Circle Seal Controls

2301 Wardlow Circle • P.O. Box 3300 • Corona, CA 92880

Phone (951) 270-6200 Fax (951) 270-6201

www.circle-seal.com • am\_sales@circle-seal.com • ind\_sales@circle-seal.com

atkomatic solenoid

# 2000 Series

## Operational Pressures (No minimum pressure differential)

### Single Wound Coils—Series 2000–2300 Metal (Stellite®) Seats

ORIFICE SIZE	GASES		LIQUIDS TO 40 SUS		LIQUIDS OVER 40 SUS		STEAM	
	AC	DC	AC	DC	AC	DC	AC	DC
1/32	8,000	3000	8,000	3000	6000	2000	300	300
3/64	3500	1,800	3500	1000	3000	750	300	300

### Single Wound Coils—Series 2000–2300 Metal Seats

ORIFICE SIZE	GASES		LIQUIDS TO 40 SUS		LIQUIDS OVER 40 SUS		STEAM	
	AC	DC	AC	DC	AC	DC	AC	DC
1/16	2500	1500	1,800	1000	1500	500	300	300
3/32	1000	500	800	350	500	170	300	300
1/8	500	200	400	125	250	60	300	125
3/16	175	55	125	35	125	15	125	35

### Single Wound Coils—Series 2000–2300 Soft Seats (Buna N, Viton®, EPR, Teflon®, and Kel-F®)

ORIFICE SIZE	GASES		LIQUIDS TO 40 SUS		LIQUIDS OVER 40 SUS		STEAM	
	AC	DC	AC	DC	AC	DC	AC	DC
1/16	2500	1,275	1500	765	1500	500	300	300
3/32	850	425	675	300	425	150	300	200
1/8	425	170	350	100	200	50	300	100
3/16	150	40	100	30	100	17	110	30

### Double Wound Coils—Series 2004–2304 Metal (Stellite®) Seats

ORIFICE SIZE	GASES		LIQUIDS TO 40 SUS		LIQUIDS OVER 40 SUS		STEAM	
	AC	DC	AC	DC	AC	DC	AC	DC
1/32	10,000	10,000	10,000	10,000	10,000	6000	300	300
3/64	9,000	4000	9,000	4000	9,000	4000	300	300

### Double Wound Coils—Series 2004–2304 Soft Seats (Buna N, Viton®, EPR, Teflon®, and Kel-F®)

ORIFICE SIZE	GASES		LIQUIDS TO 40 SUS		LIQUIDS OVER 40 SUS		STEAM	
	AC	DC	AC	DC	AC	DC	AC	DC
1/16	6000	4000	6000	3500	6000	2500	300	300
3/32	3500	2000	3000	1500	2000	1000	300	300
1/8	1000	800	600	600	500	500	300	300

Note: Rubber seats are limited to 500 psi.

## Dimensions and Shipping Weights

CATALOG NUM. PREFIX		PIPE SIZE	X	Y	Z	SHIPPING WEIGHT (lbs)
SINGLE WOUND COIL	DOUBLE WOUND COIL					
2000	2004	1/8"	7 <sup>9</sup> / <sub>16</sub> "	6"	2 <sup>3</sup> / <sub>4</sub> "	7
2100	2104	1/4"	7 <sup>9</sup> / <sub>16</sub> "	6"	2 <sup>3</sup> / <sub>4</sub> "	7
2200	2204	3/8"	7 <sup>9</sup> / <sub>16</sub> "	6"	2 <sup>3</sup> / <sub>4</sub> "	7
2300	2304	1/2"	7 <sup>9</sup> / <sub>16</sub> "	6"	2 <sup>3</sup> / <sub>4</sub> "	7

## Cv Flow Factors

ORIFICE SIZE	Cv
1/32	0.020
3/64	0.056
1/16	0.093
3/32	0.22
1/8	0.44
3/16	0.72

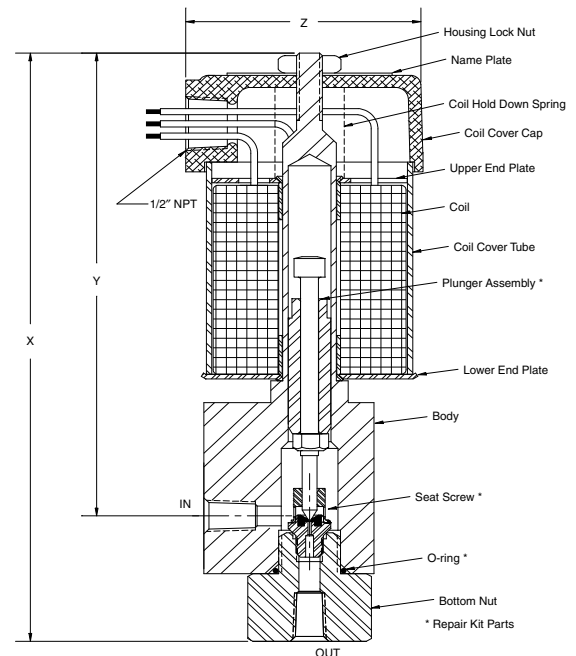

2004 Series 1/8" valve shown with NEMA 1 coil housing and a soft seat

# 2000 Series

## How to Order

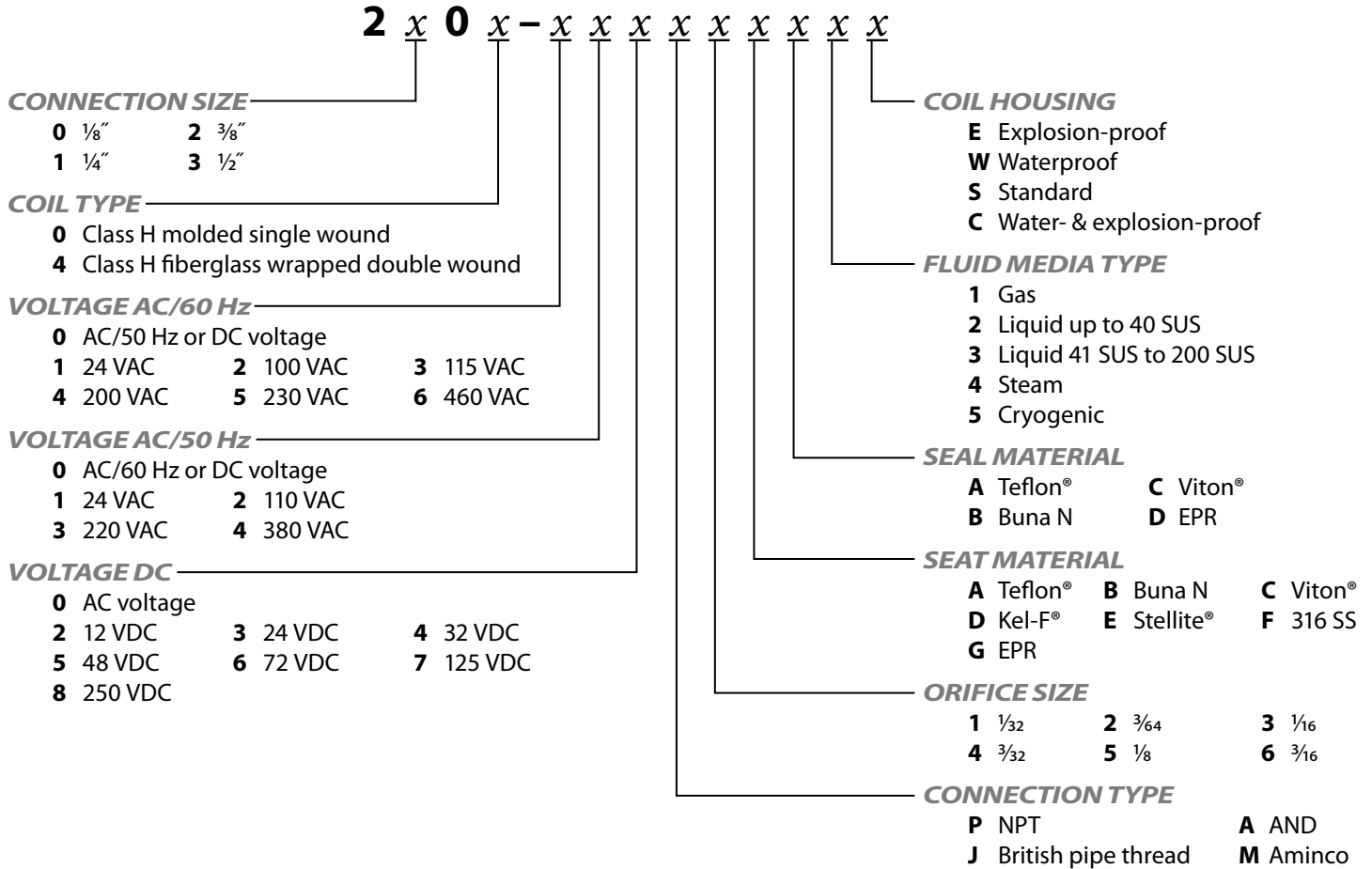

Viton® is a registered trademark of DuPont Dow Elastomers.  
 Teflon® is a registered trademark of DuPont.  
 Stellite® is a registered trademark of Deloro Stellite Company Inc.