

GO REGULATOR

UPR-7

High Flow Precision Pressure Regulator



The high flow coefficient of the UPR-7 provides the user with a high purity pressure regulator exhibiting very low droop characteristics. The combination of high flow and low droop makes the UPR-7 ideally suited for bulk gas distribution applications. The Model UPR-7 features fully electropolished internal components with standard surface finishes better than 25 Ra. This feature provides the semiconductor end-user with a precision pressure regulator, economically priced for applications ranging from gas distribution to point of use in the manufacturing tool.

Features & Specifications

- 25 Ra Internal Surface Finish, Std.
- High Flow, C_v 1.1
- Low Droop Characteristics
- 316L SS Body, Cap, Internals
- Male, Female or Internally Machined VCR Compatible Ports
- 1×10^{-9} atm cc/sec, Inboard Leak Spec

Applications

- Bulk Inert Gas Distribution
- Diffusion Furnaces
- Epitaxial Reactors
- Specialty Gas Distribution

Options

- Wetted Materials for Corrosive Service
Hastelloy, Monel

405 Centura Court
PO Box 4866
Spartanburg, SC 29303
tel 864.574.7966
fax 864.587.5608
www.goreg.com
sales@goreg.com

UPR-7

High Flow Precision Pressure Regulator

How to Order

See page 9 for standard configurations. For additional configurations, consult the factory.
See page 10 for port locations.

Maximum Temperature & Operating Inlet Pressures

Up to 100 psig Outlet Pressure			
Seat Material	Maximum Temperature*	@	Maximum Operating Inlet Pressure
Teflon®	150° F (66° C)	@	1000 psiG (6.90 MPa)
Tefzel®	175° F (80° C)	@	3600 psiG (24.82 MPa)
PCTFE (formerly Kel-F 81®)	175° F (80° C)	@	3600 psiG (24.82 MPa)
PEEK	250° F (121° C)	@	3600 psiG (24.82 MPa)
Viton®	250° F (121° C)	@	300 psiG (2.07 MPa)
Kalrez®	250° F (121° C)	@	300 psiG (2.07 MPa)

* Temperatures in excess of 175° F (80° C) require the use of a metal knob or the tamper proof option.

0–250 psig Outlet Pressure (Hand Knob)			
Seat Material	Maximum Temperature*	@	Maximum Operating Inlet Pressure
Teflon®	150° F (66° C)	@	500 psiG (3.45 MPa)
Tefzel®	175° F (80° C)	@	500 psiG (3.45 MPa)
PCTFE (formerly Kel-F 81®)	175° F (80° C)	@	500 psiG (3.45 MPa)
Viton®	250° F (121° C)	@	300 psiG (2.07 MPa)
Kalrez®	250° F (121° C)	@	300 psiG (2.07 MPa)

* Temperatures in excess of 175° F (80° C) require the use of a metal knob or the tamper proof option.

0–250 & 0–500 psig Outlet Pressures (T Handle or Tamper Proof)			
Seat Material	Maximum Temperature*	@	Maximum Operating Inlet Pressure
Teflon®	150° F (66° C)	@	1000 psiG (6.90 MPa)
PEEK	250° F (121° C)	@	3600 psiG (24.82 MPa)

* Temperatures in excess of 175° F (80° C) require the use of a metal knob or the tamper proof option.
Tefzel®, Kalvez®, Viton® and Teflon® are registered trademarks of Dupont.

Outline and Mounting Dimensions

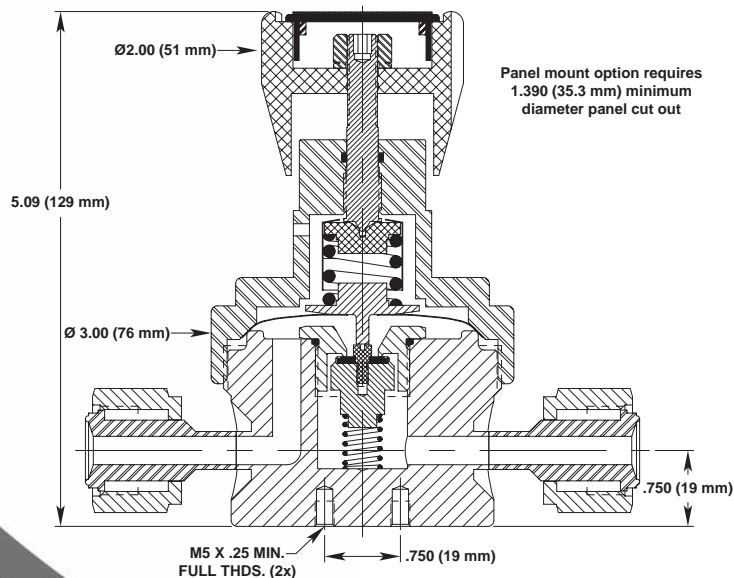

For flow curve information go to www.goreg.com/flow_upr7.htm

UPR-7 Series - Pressure Reducing Regulator

		Material of Body	
1	SS 316L		
2	Hastelloy C		
		Port Configuration (Ref. Dwg. 102191)	
A			
		Process & Gauge port	
3	1/4" FVCR Process Ports, 1/4" IVCR Gauge Ports		
4	1/4" Swivel MVCR Process Ports, 1/4" FVCR Gauge Ports		
7	1/4" IVCR Process Ports, 1/4" FVCR Gauge Ports		
A	3/8" FVCR Process Ports, 1/4" FVCR Gauge Ports		
D	3/8" Swivel MVCR Process Ports, 1/4" FVCR Gauge Ports		
G	1/2" FVCR Process Ports, 1/4" FVCR Gauge Ports		
I	1/2" FVCR Process Ports, 1/4" IVCR Gauge Ports		
J	1/2" Swivel MVCR Process Ports, 1/4" FVCR Gauge Ports		
M	3/4" FVCR Process Ports, 1/4" FVCR Gauge Ports		
N	3/4" Swivel MVCR Process Ports, 1/4" Swivel MVCR Gauge Ports		
		Surface Finish of Diaphragm Cavity	
1	<25 Ra		
		Seat Material	
A	Tefzel		
D	Viton (300 Psig Max. Inlet)		
I	Teflon		
H	PCTFE (formerly Kel-F 81)		
K	Kalrez (300 Psig Max. Inlet) (Use Alt. Price Column with 0.2 Cv)		
Q	PEEK		
		Flow Coefficient (Cv)	
5	0.2 (Use Alt. Price Column with Viton or Kalrez seat)		
8	1.1		
H	0.5		
		Outlet Range	
C	0 - 10 Psig		
D	0 - 25 Psig		
E	0 - 50 Psig		
G	0 - 100 Psig		
I	0 - 250 Psig		
J	0 - 500 Psig		
		Diaphragm Type	
1	Standard		
		Diaphragm Facing / Backing	
Dia Mat'l	1	Teflon / SS	
	2	Teflon / Viton	
	6	Tefzel Ring / SS	
	0	Teflon / Hastelloy C	
		Cap Assembly	
	1	Standard, S.S.	
	2	T-Handle, S.S.	
	7	Captured Vent, S.S.	
	8	Tamper Proof, S.S.	

U P R 7 -

Material	Port Config.	Port Style	Cavity Finish	Seat Material	Flow (Cv)	Control Range	Diaphragm Type	Diaphragm Material	Cap Assembly

PORT LOCATIONS (PRECISION PRESSURE REGULATOR)

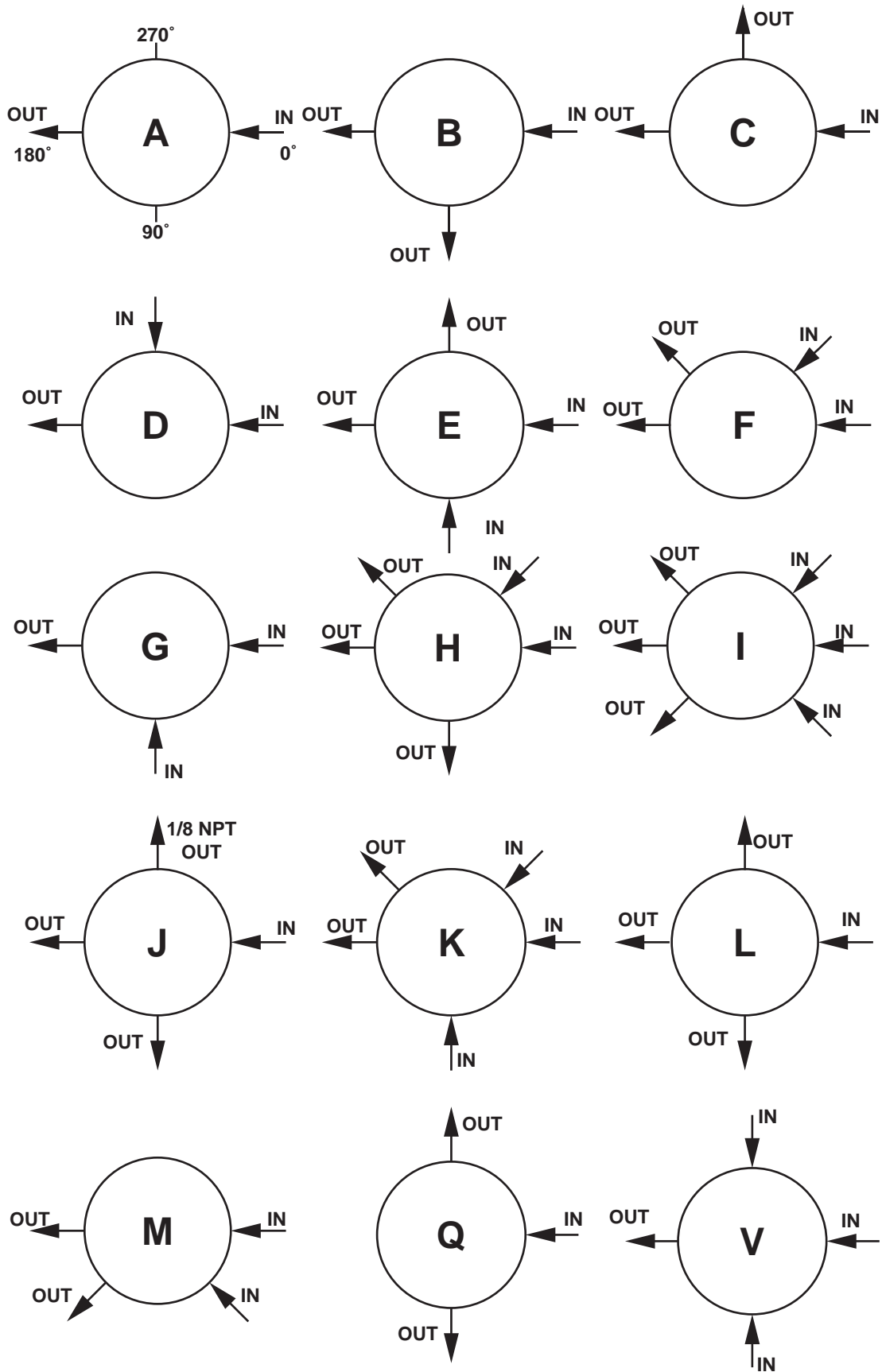

LOCATION OF PORTS FROM TOP VIEW