

GO REGULATOR

DL-57

Dome Loaded Pressure Regulator



The DL-57 is a compact and robust design which employs a unique “Dual Piston” set up that enables the users to control pressures up to 10,000 psig with as little as 58 psig of dome pressure. All of this is accomplished within the smallest envelope the industry has to offer.

The regulator portion of this unit was patterned after the time tested PR-57 Series, which is widely recognized as a benchmark of performance and quality. Offering the utmost in safety and corrosion prevention, this unit is constructed from 316L stainless steel. A carefully engineered piston sensor unit offers good sensitivity and repeatability. An independent test was run and showed that the unit's ability to repeat to a set point and low operating hysteresis is unsurpassed through out the industry.

Completing this design is the addition of an anodized aluminum (316 stainless steel optional) dome unit. The inlet ring to the dome is freely rotating and captured by a high tensile snap ring. This feature allows easy positioning and alignment of the dome gas line within a customer's system while maintaining excellent leak integrity.

Features & Specifications Applications

- | | |
|--|---|
| <ul style="list-style-type: none">• Gas or liquid service• 316L stainless steel construction; Monel optional• Better than 25 Ra finish in diaphragm cavity• Stainless steel piston sensor• 20 micron inlet filter• Bubble tight shutoff• Dome ratios 11:1, 20:1, 43:1, 56:1, 76:1, 108:1, 122:1 and 172:1• C_v flow coefficients 0.05, 0.20• Inlet/outlet ports 1/4" FNPT (standard)• Remote dome loading• Optional pressures up to 10,000 psig | <ul style="list-style-type: none">• Pilot plant• Off-shore oil and gas rigs• Pneumatic test benches• Component testing• R and D systems• High pressure booster systems |
|--|---|

405 Centura Court
PO Box 4866
Spartanburg, SC 29303
tel 864.574.7966
fax 864.587.5608
www.goreg.com
sales@goreg.com

DL-57

Dome Loaded Pressure Regulator

How to Order

See page 3 for standard configurations. For additional configurations, consult the factory.
See page 4 for port locations.

Maximum Temperature & Operating Inlet Pressures

Seat Material	Maximum Temperature	@	Maximum Operating Inlet Pressure
Polyimide	150° F (66° C)	@	10,000 psig (68.95 MPa)
PEEK	150° F (66° C)	@	10,000 psig (68.95 MPa)

Outline and Mounting Dimensions

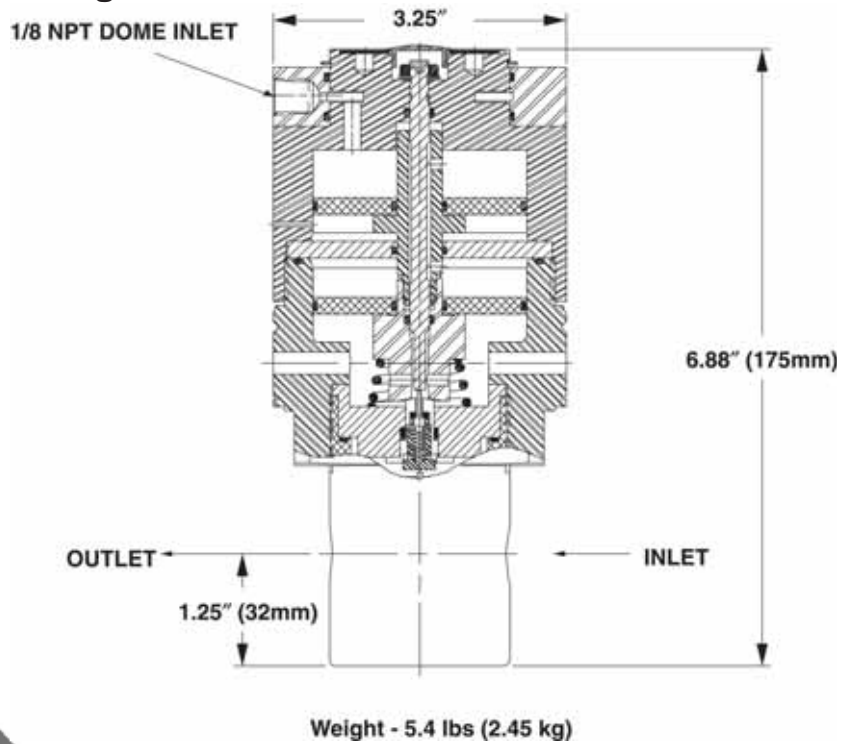

For flow curve charts, go to www.goreg.com/catalog/pr/dome/dl57/dl57_flow.htm.

DL-57 Series - Pressure Reducing Regulator

Material of Body	
1	SS 316L
4	Monel
Port Configuration (see page 4) STANDARD BODY "A" (ONE INLET PORT AND ONE OUTLET PORT)	
A	
Process port types (gauge port type, if specified)	
1	1/4" FNPT (1/4" FNPT Gauge Ports)
2	1/4" Tube (1/4" Tube Gauge Ports)
4	3/8" FNPT (1/4" FNPT Gauge Ports)
7	AN 10050-4 (1/4" FNPT Gauge Ports)
8	SAE J514 (1/4" FNPT Gauge Ports)
9	M/S 33649 (1/4" FNPT Gauge Ports)
F	1/4" Aminco (1/4" FNPT Gauge Ports)
K	1/4" Sch 40 Pipe (1/4" FNPT Gauge Ports)
Surface Finish of Diaphragm Cavity	
1	<25 Ra
5	<25 Ra with 10-32 Mounting Holes
Seat Material	
C	Polyimide
Q	PEEK
Flow Coefficient (Cv)	
2	0.05
5	0.2
Dome Ratio	
0	11 : 1
1	43 : 1
2	56 : 1
3	76 : 1
4	108 : 1
5	122 : 1
6	172 : 1
7	20 : 1
Piston Type	
1	Non Self Relieving / Viton Cavity O-Ring
2	Non Self Relieving / Teflon Cavity O-Ring
3	Self Relieving / Viton Cavity O-Ring
4	Self Relieving / Teflon Cavity O-Ring
Piston Material	
1	SS
4	Monel
Dome Style	
1	Standard, Aluminum
2	Captured Vent, Aluminum
3	S.S.
4	Captured Vent, S.S.

D L 5 7 -

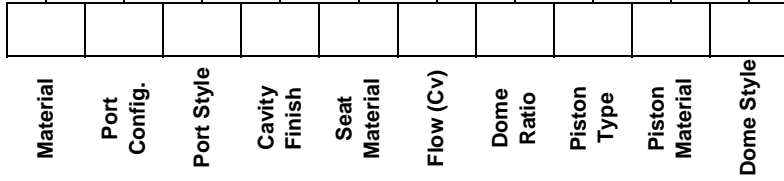

SINGLE STAGE PRESSURE REDUCING & BACK PRESSURE PORTING CONFIGURATIONS

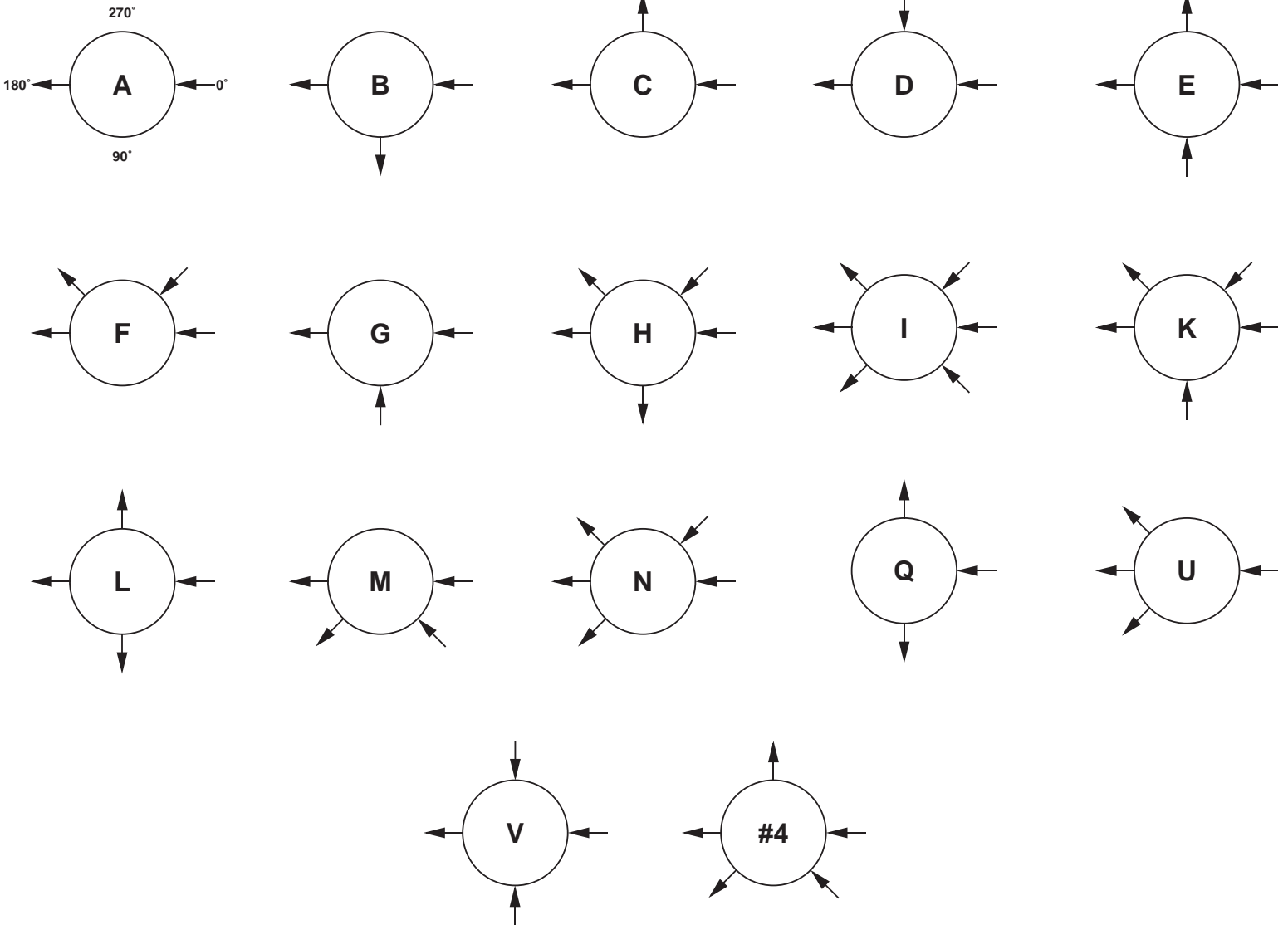

**ARROW POINTING TOWARD BODY IS INLET
ARROW POINTING AWAY FROM BODY IS OUTLET**